

Agilent E5810A

LAN/GPIB Gateway for Windows

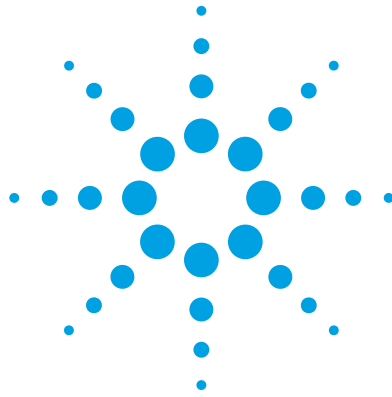

Getting Started



1 Before You Connect the E5810A

- ❑ **Using This Poster.** Use **Step 1** through **Step 4** to install and configure the E5810A LAN/GPIB Gateway for Windows. If you want to program GPIB and/or RS-232 instruments using your PC or you want to use the Agilent IO Libraries (VISA and SIDL), also do **Step 5** through **Step 8**.

NOTE

If you have difficulty installing the E5810A, see **Troubleshooting Information** on the back of this poster. For additional information on any of the steps on this poster, see the *E5810A LAN/GPIB Gateway for Windows User's Guide*.

- ❑ **Check Your Shipment Items.** In addition to this poster, your E5810A LAN/GPIB Gateway shipment should include the items listed. If items are missing or damaged, contact Agilent Technologies. See **E5810A General Information** on the back of this poster for addresses.

- *Agilent E5810A LAN/GPIB Gateway for Windows*
- *E5810A Power Cord*
- *Agilent IO Libraries for Instrument Control CD*
- *E5810A LAN/GPIB Gateway for Windows User's Guide*
- *E5810A Warranty Statement*
- *E5810A Certificate of Calibration*
- *E5810A Registration Card*
- *Software License Agreement*

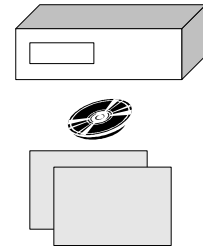

- ❑ **Check Your PC/Web Browser.** The E5810A LAN/GPIB Gateway is supported ONLY on Windows 98/NT/2000/Me/XP Professional. To communicate with the E5810A from your Web Browser, you will need Internet Explorer 4.0 or higher or Netscape 4.7 or higher.
- ❑ **Rack-Mount the E5810A (Optional).** As desired, you can mount the E5810A in a standard EIA rack using the E5810-00100 Rack Mount Kit (or equivalent). The E5810A is one standard half-rack unit wide and one standard rack unit high. See the E5810-00100 Rack Mount Kit for instructions.

2 Install the E5810A

- ❑ **Connect the E5810A to the Network and to Instruments.** This figure shows typical network and instrument connections for the E5810A. Make connections as required for your application. See the *E5810A LAN/GPIB Gateway for Windows User's Guide* for detailed connections.

IMPORTANT

BEFORE making any Enterprise (corporate) network connections, contact your Information Technology (IT) department for policies concerning user connections, IP addresses, etc. See **Contacting Your IT Department** on the back of this poster for suggested actions.

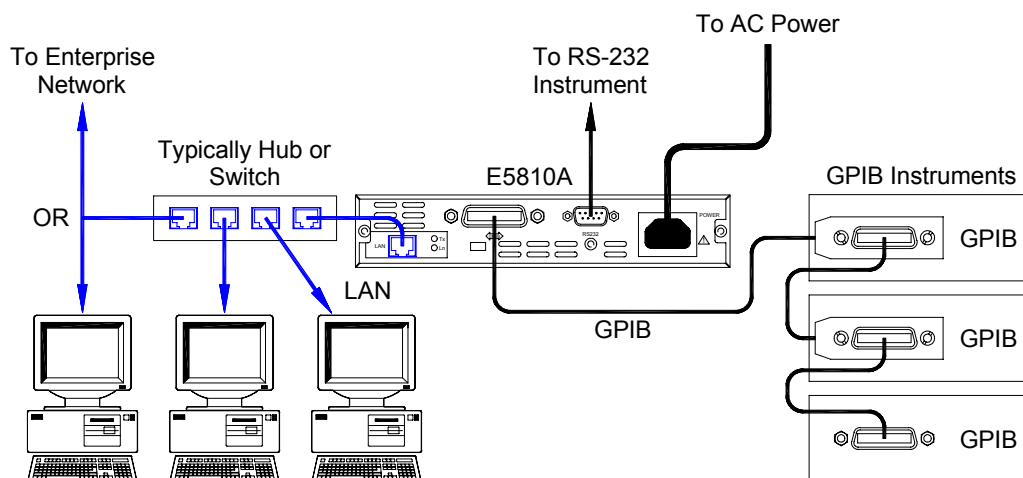

- ❑ **Apply Power to the E5810A.** Plug the E5810A power cord into the E5810A POWER socket. Then, plug the cord into an AC outlet and observe the E5810A display. After an initial setup period, the E5810A IP address and hostname (if recognized) should appear on the display. If the IP address does not appear, see **Troubleshooting Information** on the back of this poster.

3 Configure the E5810A

- ❑ **Display the E5810A Welcome Page.** To display the E5810A **Welcome** page, on your web browser type 'http://<hostname>', where <hostname> is the Hostname of the E5810A **OR** type 'http://<IP address>', where <IP address> is the current E5810A IP address (such as 169.254.58.10) shown on the E5810A display. Then, press **Enter**.

NOTE

If the **Welcome** page does not display correctly, you may need to change your web browser settings. See **Configuring Your Web Browser** on the back of this poster for details.

The screenshot shows the E5810A web interface. On the left is a navigation bar with icons for: Welcome Page, View & Modify Configuration, Find & Query Instruments, Session Status, Print Page, and Help with this Page. On the right is the 'Welcome to your Web-Enabled E5810 LAN/GPIB Gateway' page. It includes a section for 'Your Current Settings are:' with a table of settings, and a section for 'E5810 Documentation' with links for 'Help' and 'User's Guide'.

Your Current Settings are:	
Ethernet (MAC) Address:	00-30-D3-05-00-23
Hostname:	hpl/tb6
IP Address:	156.140.104.234
GPIB SIDL Interface Name:	gpib0
RS-232 SIDL Interface Name:	COM1
Firmware Revision:	A.00.11
Serial Number:	US12345678

E5810 Documentation:

- [Help](#)
- [User's Guide](#)

Annotations: A box on the left says 'Click this icon to View and Modify Configuration' with an arrow pointing to the 'View & Modify Configuration' icon. Another box says 'Click this icon to Find and Query Instruments' with an arrow pointing to the 'Find & Query Instruments' icon. A box on the right says 'Current E5810A Settings on Display' with an arrow pointing to the settings table.

- ❑ **View/Modify Current Configuration (Optional).** To view current configuration settings (and change settings as desired), click the **View and Modify Configuration** icon and enter the password (the default password is **E5810**) to display the **Current Configuration of the E5810 LAN/GPIB Gateway** page. Click the **Modify Configuration** button to enable you to change settings. After making changes, click **Save** and then **Reboot E5810** to make changes effective.

4 Verify Communication From E5810A

- ❑ **Verifying Communication from the E5810A.** From the E5810A **Welcome** page, click the **Find & Query Instruments** icon and enter the password (default password is **E5810**) to display the **Instrument** page. See the following figure for ways to verify communication with instruments using the E5810A **Instrument** page.

Click Device Clear, *IDN?, Read STB, systerr?, or Clear History

OR

Enter command on Instrument Command line and then click **Send**, **Receive**, or **Query** (sends and receives)

Selected Instrument

- ❑ **Send Commands and Queries to Instruments.** To interact with instruments from the E5810A **Instrument** page, highlight the instrument to be addressed and type an instrument command on the Instrument Command line. (See your instrument manual for instrument commands.) Then, click **Send**, **Receive**, or **Query** as applicable. The following example shows one way to return a DC voltage measurement from an instrument.

1. Highlight Instrument

2. Type Command

3. Click Query

4. Read Response

5 Install the Agilent IO Libraries

- ❑ **Introduction.** To remotely program your instruments on client PCs, you must install the Agilent IO Libraries on each PC to be used for programming.
- ❑ **Insert the Agilent IO Libraries CD.** Turn on your PC and insert the *Agilent Technologies IO Libraries for Instrument Control* CD (Version L.01.01 or later) into the CD-ROM drive. If the installer is not automatically activated, click **Start | Run** and type `<drive>:SETUP.EXE`
- ❑ **Install the Agilent IO Libraries.** When the Agilent IO Libraries display appears, follow the on-screen instructions to install the libraries. Using the "Full Installation" option is recommended for most applications. If you want to do a custom installation of the Agilent IO Libraries, see *the Agilent E5810A LAN/GPIB Gateway for Windows User's Guide*.
- ❑ **Look for the Blue IO Icon.** After the libraries are installed, a blue **IO** icon is displayed on the Windows taskbar at the bottom-right corner of the screen.



- ❑ **Display the IO Config Main Screen.** To remotely program instruments using VISA, you must use the IO Config utility to configure your PC for VISA LAN Client operation. To display the IO Config utility main screen, click the blue **IO** icon on the Windows taskbar and click **Run IO Config**
- ❑ **Set VISA LAN Client.** Go to **Step 6** (for GPIB instruments) and/or to **Step 7** (for RS-232 instruments) to configure your PC for VISA LAN Client.

6 Configure VISA LAN Client (GPIB)

- ❑ **Select VISA LAN Client (GPIB Instruments).** To configure the interface for GPIB instruments, from the IO Config utility main screen highlight **GPIB VISA LAN Client (e.g. 5810)** and click **Configure** to display the **VISA LAN Client Interface (LAN to GPIB)** dialog box.

1. Highlight **GPIB VISA LAN Client**

2. Click **Configure**

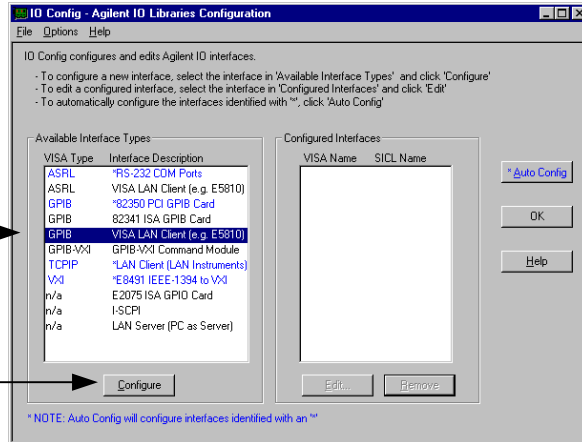

- ❑ **Configure for VISA LAN Client.** From the **VISA LAN Client Interface (LAN to GPIB)** dialog box, follow the steps shown and click **OK** to select the settings.

1. Change this value to the Hostname **OR** to the IP Address shown on the E5810A display.

2. Change this value to the **GPIB SICL Interface Name** displayed on the E5810A Welcome Page (see Step 3).

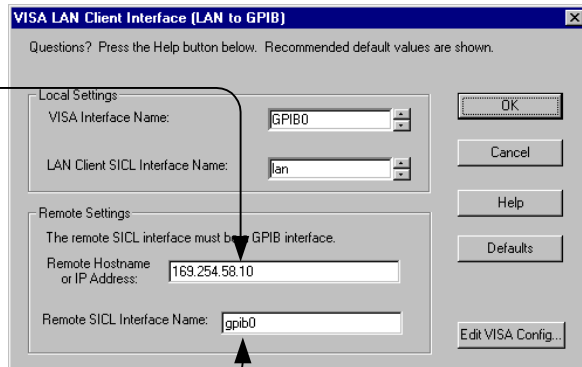

7 Configure VISA LAN Client (RS-232)

- ❑ **Select VISA LAN Client (RS-232 Instruments).** To configure the interface for RS-232 (ASRL) instruments, from the IO Config utility main screen highlight **ASRL VISA LAN Client (e.g. 5810)** and click **Configure** to display the **VISA LAN Client Interface (LAN to ASRL)** dialog box.

1. Highlight **VISA LAN Client**

2. Click **Configure**

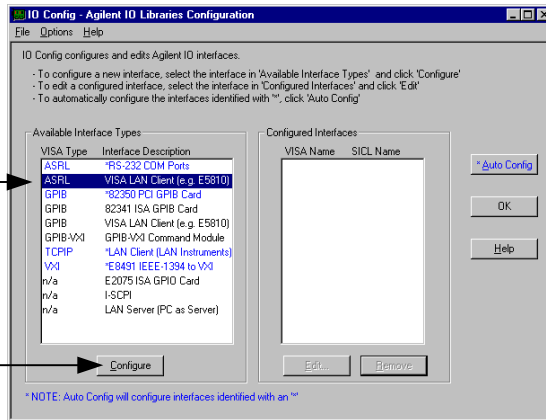

- ❑ **Configure for VISA LAN Client.** From the **VISA LAN Client Interface (LAN to ASRL)** dialog box, follow the steps shown and click **OK** to select the settings.

1. Change this value to the Hostname **OR** to the IP Address shown on the E5810A display.

2. Change this value to the **RS-232 SICL Interface Name** displayed on the E5810A Welcome Page (see Step 3).

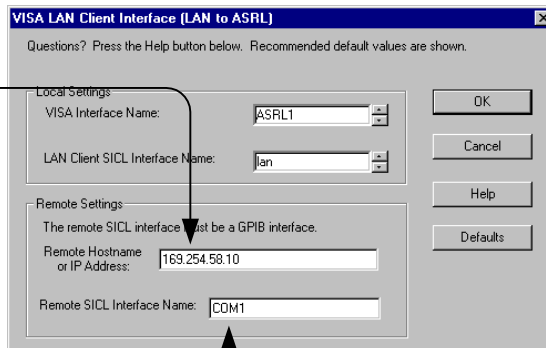

8 Verify Communication From PC

- ❑ **Introduction.** After the Agilent IO Libraries have been installed and configured, you can use the *VISA Assistant* utility or a supported programming language to verify communication from your PC to GPIB or RS-232 instruments.
- ❑ **Verifying Instrument Communication Using VISA Assistant.** After your PC has been configured for VISA LAN Client operation, you can communicate with instruments using the *VISA Assistant* utility. To access the VISA Assistant main screen, click the blue **IO** icon located on the Windows taskbar and click **Run VISA Assistant**. This example shows steps you can use to return the ID string for an IEEE 488.2-compliant instrument.

The screenshot shows the VISA Assistant application window. The left pane displays a tree view of instrument connections under 'GPIB1', with 'GPIB1::9::8::INSTR' highlighted. The main pane shows the 'Formatted I/O' tab with a command history containing '>*IDN?' and the response '<HEWLETT-PACKARD.B1413B.US34001461.A.03.05'. The right pane has buttons for '*IDN?', '*RST?', and '*TST?'. The bottom right pane shows 'Instr. Lang.' options: 'Custom', 'IEEE 488.2' (selected), and 'SCPI'. Five callout boxes provide instructions: 1. Highlight Instrument to be addressed (points to the tree view), 2. Select Formatted IO Tab (points to the 'Formatted I/O' tab), 3. Select IEEE 488.2 button (points to the 'IEEE 488.2' radio button), 4. Click *IDN? button (points to the '*IDN?' button), and 5. Repeat 1 - 4 for next instrument (points to the right side of the window).

1. Highlight Instrument to be addressed
2. Select Formatted IO Tab
3. Select IEEE 488.2 button
4. Click *IDN? button
5. Repeat 1 - 4 for next instrument

- ❑ **Verifying Instrument Communication Using Programming Languages.** You can also verify communication with GPIB and RS-232 instruments using a supported programming language. See [E5810A Documentation/Support](#) on the back of this poster for applicable documentation.

Contacting Your IT Department

- ❑ **Before You Connect the E5810A.** Before you connect your E5810A to an Enterprise (Corporate) network, copy the E5810A Serial Number and Ethernet (MAC) address (located on the underside of the E5810A) in the space provided on the following *E5810A LAN/GPIB Gateway Information* card.

E5810A LAN/GPIB Gateway Information

Serial Number: _____
Ethernet (MAC) Hardware Address: _____

Default Values (for IT Department): **DHCP:** Enabled at power-on
Hostname: No hostname configured

- ❑ **Ask Your IT Department for Network Configuration Information.** After you enter the E5810A Serial Number and Hardware Address, copy this page and provide the copy to your IT department. Ask them to answer the following questions and return the completed form to you.

NOTE

If the Enterprise network does not support DHCP, see [Configure E5810A Using Local Network](#) to configure the E5810A using a Local network.

Enterprise Network Information

Does the Network Support DHCP? Yes ___ No ___

If No, provide: IP Address (Static): _____
Subnet Mask: _____
Gateway IP Address: _____

Does the Network Support DNS? Yes ___ No ___

If Yes, provide: E5810A Hostname: _____
DNS Server (IP Address): _____

Configure E5810A Using Local Network

- ❑ **Introduction.** If your Enterprise (corporate) network does **not** support DHCP, when the E5810A is connected to the network the E5810A will use its default static IP address (169.254.58.10), which may not be valid on the network. In this case, you must use a Local network (Isolated LAN) to configure the E5810A for correct operation on the Enterprise network.
- ❑ **Setting Up a Local Network.** A Local network consists of a computer with an Ethernet port and an E5810A. Two example configurations follow.

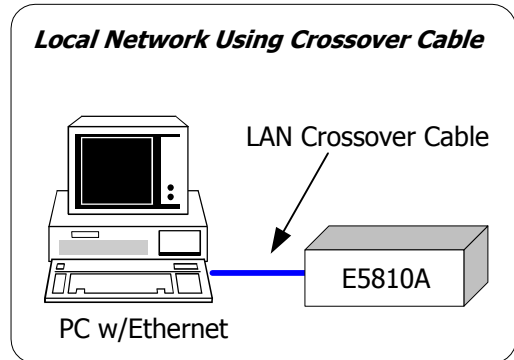
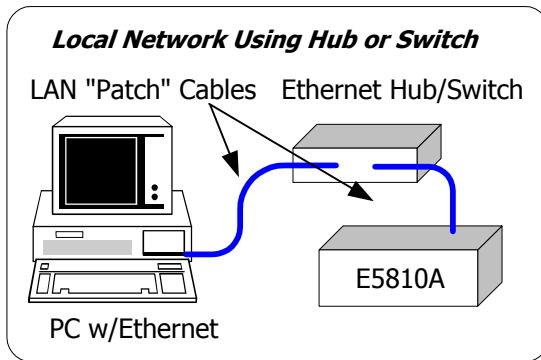

- ❑ **Configuring the E5810A.** To configure the E5810 using your web browser:
 1. Start your web browser and type in the E5810A IP Address.
 2. Click the **View and Modify Configuration** icon to display the **Current Configuration of the E5810 LAN/GPIB Gateway** page.
 3. Click **Modify Configuration**, enter the E5810A password (default is E5810) and click **Submit** to show the **Configuring your E5810 LAN/GPIB Gateway** page.
 4. Set DHCP OFF and update the static IP address, subnet mask, and default gateway parameters provided by your System Administrator.
 5. If you are using DNS, enter the IP Address of the Domain Name Server and hostname provided by your System Administrator.
 6. Click **Save** to save changes and then click **Reboot E5810** to reboot the E5810 and have the changes take effect.
 7. Disconnect the E5810A from the Local network and connect the E5810A to the Enterprise network.

Configuring Your Web Browser

- ❑ **Introduction.** The E5810A Internet interface generates web pages that depend on Javascript and Frames. For best results, you may need to configure the Enable Javascript, Cache and Page Refresh, and Proxies options on your web browser. Some guidelines follow. See the *E5810A LAN/GPIB Gateway for Windows User's Guide* for steps to set your web browser.

- ❑ **Enabling Javascript.** If the E5810A detects that Javascript is not enabled, a dialog box appears on the E5810A **Welcome** page that displays instructions to enable Javascript for Internet Explorer and Netscape Navigator.

Fix: Follow the instructions to enable Javascript. If Javascript is not enabled, you will not be able to use the **View and Modify Configurations** page or the **Find and Query Instruments** page of the interface.

- ❑ **Cache and Page Refresh.** Typically, web browsers cache web pages to store an image of the web page locally. When you navigate to an already viewed page, the page is loaded from cache rather than from the network. This is acceptable for "static" web pages in which information does not change. However, the E5810A uses "dynamic" web pages in which information can quickly change.

Fix: To avoid displaying outdated information on the web pages, the "Check for newer versions of stored pages" (or equivalent) option on your web browser should be set for "Every visit to the page" (or equivalent).

- ❑ **Proxies.** If you are using a proxy server, the web page may time out, even though the correct IP address or hostname is entered into the web browser.

Fix: To correct this problem, the browser must be informed that any requests to the E5810A should **not** use a proxy. To do this, add the IP address of the E5810A to the list box "Do not use proxy server for addresses beginning with:" (or equivalent).

E5810A Documentation/Support

- ❑ **E5810A Related Documentation.** See the following documents for information related to the E5810A. When the Agilent IO Libraries are installed, all documents are available in electronic format by clicking the blue **IO** icon on the Windows taskbar and selecting **View Documentation**.
 - *Agilent E5810A LAN/GPIB Gateway for Windows User's Guide* describes the E5810A and provides installation and troubleshooting information.
 - *Agilent IO Libraries Installation and Configuration Guide for Windows* provides a description of the Agilent IO Libraries.
 - *Agilent VISA User's Guide* describes the Agilent Virtual Instrument Software Architecture (VISA) library.
 - *Agilent SICL User's Guide for Windows* describes the Agilent Standard Instrument Control Library (SICL) for Windows.
- ❑ **E5810A Support Information.** See the following web sites or contact Agilent at the numbers shown.

Agilent Technologies Telephone Numbers

Americas Call Center:	1-800-452-4844
Canada Call Center:	1-877-894-4414
European Call Center:	+31-20-547-9900
Japan Call Center:	+81-426-56-7832

World-Wide Websites

www.agilent.com/find/assist	For the Agilent main website
www.agilent.com/find/e5810a	For E5810A info/firmware updates
www.agilent.com/find/iolib	To download Agilent IO Libraries
www.agilent.com/find/manuals	To access manuals and app notes
www.agilent.com/find/connectivity	<i>Agilent's T&M Programmer's Toolkit for Visual Studio.NET</i>

Troubleshooting Information

- ❑ **Introduction.** If you have communication or operation problems with the E5810A LAN/GPIB Gateway, you can use this information to help you identify the problem and take corrective action. See the *E5810A LAN/GPIB Gateway for Windows User's Guide* for further troubleshooting information.
- ❑ **Check Display/LEDs.** Check front panel display/LEDs and back panel Ln LED.

Status	Possible Cause(s)	Corrective Action(s)
All LEDs OFF	NO AC power to E5810A	Check AC power connections
Only POWER and FAULT ON	If FAULT is ON after 10 sec, suspect hardware failure	Contact Agilent for instructions to return E5810A
POWER ON, Back Panel Ln LED OFF	Indicates no communication from PC to E5810A via LAN	Check LAN connection to E5810A
POWER and LAN ON, GPIB and/or RS-232 OFF	Indicates communication via LAN to E5810A, but not to GPIB and/or RS-232 instr	Check GPIB and/or RS-232 connections and configuration

- ❑ **Network Configuration.** Check the network for configuration problems.

Status	Possible Cause(s)	Corrective Action(s)
Cannot access E5810A Internet Interface	Improper network installation	Check network installation or contact System Administrator
	Missing/improper web addresses	See "Contacting Your IT Dept"
	Improper Web Server settings	See "Configuring Your Web Browser"
No password	Unknown or forgotten password	Use Preset button to reset to factory default (E5810)

Troubleshooting Information

- ❑ **Instrument Configuration.** Check GPIB/RS-232 Instrument setups.

Symptom	Possible Cause(s)	Corrective Action(s)
Cannot send commands to one or more GPIB instruments	<p>Intermittent or missing GPIB connection</p> <p>GPIB device power not ON or defective GPIB device</p> <p>No instrument communication</p> <p>VISA/SICL not configured</p>	<p>Check GPIB connections</p> <p>Make sure GPIB device power is ON and device is operating properly</p> <p>Try to communicate with instruments (see Step 4)</p> <p>Configure for VISA LAN Client (see Steps 5 through 8)</p>
Cannot communicate with RS-232 instrument	<p>Intermittent or missing RS-232 connection</p> <p>RS-232 device power not ON or defective RS-232 device</p> <p>No RS-232 device communication</p> <p>RS-232 interface not configured for attached device</p> <p>VISA/SICL not configured</p>	<p>Check RS-232 connections and configuration</p> <p>Make sure RS-232 device power is ON and device is operating properly</p> <p>Try to communicate with device (see Step 4)</p> <p>Change E5810A RS-232 interface attributes to match RS-232 device attributes (baud rate, parity, etc.)</p> <p>Configure for VISA LAN Client (see Steps 5 through 8)</p>

INSTALLING AND CONFIGURING THE E5810A

INSTALLING AND CONFIGURING IO LIBRARIES

E5810A GENERAL INFORMATION

TROUBLESHOOTING



Agilent Technologies



Part Number: E5810-90100
Printed in U.S.A. E0502



Agilent Technologies

